



FOOD EQUIPMENT

SERVING THE FOOD INDUSTRY SINCE 1951

**72-INCH STAINLESS STEEL ELECTRIC OPEN WELL
HOT FOOD TABLE WITH 5 PANS CAPACITY, CUTTING
BOARD AND UNDERSHELF**

Item: 46648 Model: FW-CN-0005-FH

**KEEP YOUR HOT FOODS
READILY AVAILABLE AT
SAFE TEMPERATURE**

Perfect for buffet and catering services, Omcan's 72-inch Stainless Steel Electric Open Well Hot Food Table with Cutting Board and Undershef is designed to keep your hot foods readily available at safe temperature. With a durable stainless steel construction, this food warmer has a convenient undershef where you could store extra serving utensils, food pans, or any other kitchen tools that you need, as well as a polycarbonate cutting board as an extra work space in case you need to fill out food pans or plates.



Pans not included.



WARRANTY
PARTS AND LABOR



Authorized Dealer

TECHNICAL SPECIFICATIONS

ITEM NUMBER	46648
MODEL	FW-CN-0005-FH
MAX. TEMPERATURE	Approximately 212°F / 100°C
POWER	5000W
ELECTRICAL	240V / 60Hz / 1Ph
AMPS	20.83
MATERIAL	Stainless Steel
CUTTING BOARD MATERIAL	Polyethylene
NUMBER OF PANS	5 (Pans not included)
PAN SIZE	20.78" x 12.8" x 6" (full size)
UNDERSHELF SIZE	69.7" x 18" x 2" 1770 x 462 x 50 mm
CUTTING BOARD SIZE	72" x 7.9" x 0.5" 1830 x 200 x 12 mm
DIMENSIONS (WDH)	72" x 30" x 34" 1830 x 772 x 870 mm
GROSS DIMENSIONS	75" x 25" x 20" 1910x640x520mm
WEIGHT	68kgs. 150lbs.
GROSS WEIGHT	88kg. 194lbs.

FEATURES

- Stainless steel structure with individual control
- Adjustable stainless steel undershelf and removable Polyethylene cutting board
- Adjustable stainless steel feet
- Stainless steel heating element
- 5 independent infinite controls
- Pans not included

OPTIONAL ACCESSORIES

- Full Size Pan (Item 80258)
- Spillage Pan (Item 80907)

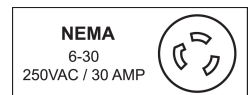

TECHNICAL DRAWINGS AND DIMENSIONS

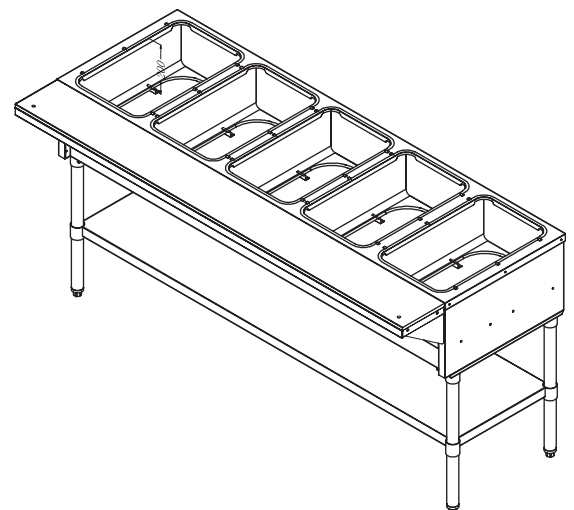
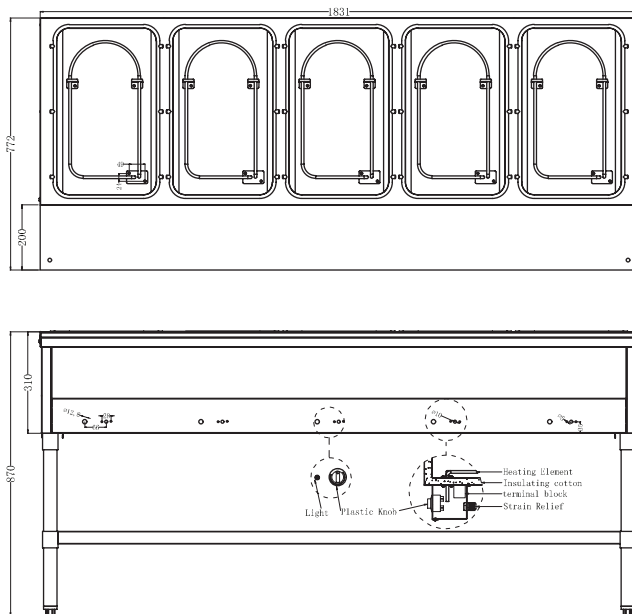

OMCAN INC.

Telephone: 1-800-465-0234
 Fax: (905) 607-0234
 Email: sales@omcan.com
 Website: www.omcan.com



Follow us to keep up to date with the latest news and offers

